

रोल नं.  
Roll No. 

--	--	--	--	--	--	--

परीक्षार्थी कोड को उत्तर-पुस्तिका के मुख-पृष्ठ पर अवश्य लिखें।

Candidates must write the Code on the title page of the answer-book.

- कृपया जाँच कर लें कि इस प्रश्न-पत्र में मुद्रित पृष्ठ 19 हैं।
- प्रश्न-पत्र में दाहिने हाथ की ओर दिए गए कोड नम्बर को छात्र उत्तर-पुस्तिका के मुख-पृष्ठ पर लिखें।
- कृपया जाँच कर लें कि इस प्रश्न-पत्र में 26 प्रश्न हैं।
- कृपया प्रश्न का उत्तर लिखना शुरू करने से पहले, प्रश्न का क्रमांक अवश्य लिखें।
- इस प्रश्न-पत्र को पढ़ने के लिए 15 मिनट का समय दिया गया है। प्रश्न-पत्र का वितरण पूर्वाह्न में 10.15 बजे किया जाएगा। 10.15 बजे से 10.30 बजे तक छात्र केवल प्रश्न-पत्र को पढ़ेंगे और इस अवधि के दौरान वे उत्तर-पुस्तिका पर कोई उत्तर नहीं लिखेंगे।
- Please check that this question paper contains 19 printed pages.
- Code number given on the right hand side of the question paper should be written on the title page of the answer-book by the candidate.
- Please check that this question paper contains 26 questions.
- **Please write down the Serial Number of the question before attempting it.**
- 15 minute time has been allotted to read this question paper. The question paper will be distributed at 10.15 a.m. From 10.15 a.m. to 10.30 a.m., the students will read the question paper only and will not write any answer on the answer-book during this period.

## भौतिक विज्ञान (सैद्धान्तिक)

### PHYSICS (Theory)

निर्धारित समय : 3 घण्टे

अधिकतम अंक : 70

Time allowed : 3 hours

Maximum Marks : 70



### सामान्य निर्देश :

- (i) सभी प्रश्न अनिवार्य हैं। इस प्रश्न-पत्र में कुल 26 प्रश्न हैं।
- (ii) इस प्रश्न-पत्र के पाँच भाग हैं: खण्ड अ, खण्ड ब, खण्ड स, खण्ड द और खण्ड य।
- (iii) खण्ड अ में पाँच प्रश्न हैं, प्रत्येक का एक अंक है। खण्ड ब में पाँच प्रश्न हैं, प्रत्येक के दो अंक हैं। खण्ड स में बारह प्रश्न हैं, प्रत्येक के तीन अंक हैं। खण्ड द में चार अंक का एक मूल्याधारित प्रश्न है और खण्ड य में तीन प्रश्न हैं, प्रत्येक के पाँच अंक हैं।
- (iv) प्रश्न-पत्र में समग्र पर कोई विकल्प नहीं है। तथापि, दो अंकों वाले एक प्रश्न में, तीन अंकों वाले एक प्रश्न में और पाँच अंकों वाले तीनों प्रश्नों में आन्तरिक चयन प्रदान किया गया है। ऐसे प्रश्नों में आपको दिए गए चयन में से केवल एक प्रश्न ही करना है।
- (v) जहाँ आवश्यक हो, आप निम्नलिखित भौतिक नियतांकों के मानों का उपयोग कर सकते हैं :

$$c = 3 \times 10^8 \text{ m/s}$$

$$h = 6.63 \times 10^{-34} \text{ Js}$$

$$e = 1.6 \times 10^{-19} \text{ C}$$

$$\mu_0 = 4\pi \times 10^{-7} \text{ T m A}^{-1}$$

$$\epsilon_0 = 8.854 \times 10^{-12} \text{ C}^2 \text{ N}^{-1} \text{ m}^{-2}$$

$$\frac{1}{4\pi\epsilon_0} = 9 \times 10^9 \text{ N m}^2 \text{ C}^{-2}$$

$$\text{इलेक्ट्रॉन का द्रव्यमान} = 9.1 \times 10^{-31} \text{ kg}$$

$$\text{न्यूट्रॉन का द्रव्यमान} = 1.675 \times 10^{-27} \text{ kg}$$

$$\text{प्रोटॉन का द्रव्यमान} = 1.673 \times 10^{-27} \text{ kg}$$

$$\text{आवोगाद्रो संख्या} = 6.023 \times 10^{23} \text{ प्रति ग्राम मोल}$$

$$\text{बोल्ट्ज़मान नियतांक} = 1.38 \times 10^{-23} \text{ JK}^{-1}$$



### **General Instructions :**

- (i) **All** questions are compulsory. There are **26** questions in all.
- (ii) This question paper has **five** sections : Section A, Section B, Section C, Section D and Section E.
- (iii) Section A contains **five** questions of **one** mark each, Section B contains **five** questions of **two** marks each, Section C contains **twelve** questions of **three** marks each, Section D contains one value based question of **four** marks and Section E contains **three** questions of **five** marks each.
- (iv) There is no overall choice. However, an internal choice has been provided in **one** question of **two** marks, **one** question of **three** marks and all the **three** questions of **five** marks weightage. You have to attempt only **one** of the choices in such questions.
- (v) You may use the following values of physical constants wherever necessary :

$$c = 3 \times 10^8 \text{ m/s}$$

$$h = 6.63 \times 10^{-34} \text{ Js}$$

$$e = 1.6 \times 10^{-19} \text{ C}$$

$$\mu_0 = 4\pi \times 10^{-7} \text{ T m A}^{-1}$$

$$\epsilon_0 = 8.854 \times 10^{-12} \text{ C}^2 \text{ N}^{-1} \text{ m}^{-2}$$

$$\frac{1}{4\pi\epsilon_0} = 9 \times 10^9 \text{ N m}^2 \text{ C}^{-2}$$

$$\text{Mass of electron} = 9.1 \times 10^{-31} \text{ kg}$$

$$\text{Mass of neutron} = 1.675 \times 10^{-27} \text{ kg}$$

$$\text{Mass of proton} = 1.673 \times 10^{-27} \text{ kg}$$

$$\text{Avogadro's number} = 6.023 \times 10^{23} \text{ per gram mole}$$

$$\text{Boltzmann constant} = 1.38 \times 10^{-23} \text{ JK}^{-1}$$



**खण्ड अ**  
**SECTION A**

1. यदि बैंगनी रंग के आपतित प्रकाश को लाल प्रकाश से प्रतिस्थापित कर दिया जाए, तो काँच के प्रिज़्म का न्यूनतम विचलन कोण किस प्रकार परिवर्तित होगा ? कारण दीजिए । 1

How does the angle of minimum deviation of a glass prism vary, if the incident violet light is replaced by red light ? Give reason.

2. उस परिघटना का नाम लिखिए जो विद्युत्-चुम्बकीय विकिरणों की क्वान्टम प्रकृति को दर्शाती है । 1

Name the phenomenon which shows the quantum nature of electromagnetic radiation.

3. जब तार में प्रवाहित धारा I में नियमित रूप से वृद्धि हो रही है, तो धातु के वलयों 1 और 2 में प्रेरित धाराओं की दिशा क्या है ? 1

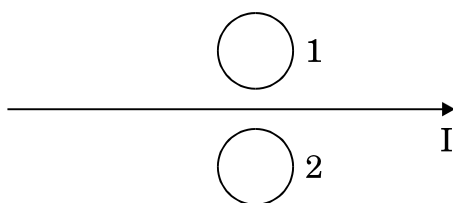

What is the direction of induced currents in metal rings 1 and 2 when current I in the wire is increasing steadily ?

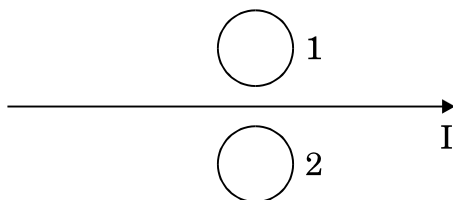

4. x-अक्ष के अनुदिश संचरण करने वाली किसी विद्युत्-चुम्बकीय तरंग के विद्युत् और चुम्बकीय क्षेत्र सदिश किन दिशाओं में दोलन करते हैं ? 1

In which directions do the electric and magnetic field vectors oscillate in an electromagnetic wave propagating along the x-axis ?

5. समान लम्बाई और समान त्रिज्या के निक्रोम और ताँबे के तार श्रेणीक्रम में संयोजित हैं। इनमें से धारा I प्रवाहित कराई गई है। कौन-सा तार अधिक तप्त होगा? अपने उत्तर की पुष्टि कीजिए।

1

Nichrome and copper wires of same length and same radius are connected in series. Current I is passed through them. Which wire gets heated up more? Justify your answer.

### खण्ड ब

### SECTION B

6. (a) स्थायी चुम्बक, और (b) विद्युत्-चुम्बक बनाने के लिए उपयुक्त पदार्थ के दो गुण लिखिए।  
Write two properties of a material suitable for making (a) a permanent magnet, and (b) an electromagnet. 2
7. एकल झिरी विवर्तन और द्वि झिरी व्यतिकरण के लिए तीव्रता पैटर्न खींचिए। अतः इस प्रकार व्यतिकरण और विवर्तन पैटर्नों के बीच दो अन्तरों का उल्लेख कीजिए। 2

### अथवा

अध्रुवित प्रकाश किसी पोलैराइड  $P_1$  से गुजरता है। जब यह ध्रुवित प्रकाश पुंज किसी अन्य पोलैराइड  $P_2$  से गुजरता है तथा यदि  $P_2$  का पास-अक्ष  $P_1$  के पास-अक्ष से  $\theta$  कोण बनाता है, तब  $P_2$  से गुजरने वाले ध्रुवित प्रकाश पुंज के लिए व्यंजक लिखिए। जब  $\theta$  का मान 0 से  $2\pi$  के बीच विचरण करता है, तो तीव्रता में विचरण को दर्शाने के लिए ग्राफ़ खींचिए। 2

Draw the intensity pattern for single slit diffraction and double slit interference. Hence, state two differences between interference and diffraction patterns.

### OR

Unpolarised light is passed through a polaroid  $P_1$ . When this polarised beam passes through another polaroid  $P_2$  and if the pass axis of  $P_2$  makes angle  $\theta$  with the pass axis of  $P_1$ , then write the expression for the polarised beam passing through  $P_2$ . Draw a plot showing the variation of intensity when  $\theta$  varies from 0 to  $2\pi$ .



8. किसी बैटरी के सिरों से संयोजित किसी संधारित्र से स्थायी अवस्था में कोई धारा क्यों प्रवाहित नहीं होती ? यद्यपि उसी संधारित्र को आवेशित करते अथवा निरावेशित करते समय क्षणिक धारा प्रवाहित होती है । व्याख्या कीजिए ।

2

Why does current in a steady state not flow in a capacitor connected across a battery ? However momentary current does flow during charging or discharging of the capacitor. Explain.

9. हाइड्रोजन परमाणु की न्यूनतम अवस्था ऊर्जा  $-13.6$  eV है । यदि कोई इलेक्ट्रॉन ऊर्जा स्तर  $-1.51$  eV से  $-3.4$  eV पर संक्रमण करता है, तो उत्सर्जित स्पेक्ट्रमी रेखा की तरंगदैर्घ्य परिकलित कीजिए और हाइड्रोजन स्पेक्ट्रम की उस श्रेणी का नाम लिखिए जिससे यह सम्बन्धित है ।

2

The ground state energy of hydrogen atom is  $-13.6$  eV. If an electron makes a transition from an energy level  $-1.51$  eV to  $-3.4$  eV, calculate the wavelength of the spectral line emitted and name the series of hydrogen spectrum to which it belongs.

10. उस स्थिति को ज्ञात कीजिए जिनमें विद्युत् और चुम्बकीय क्षेत्र सदिशों की उपस्थिति में विभिन्न चालों से गतिमान आवेशित कणों का उपयोग किसी विशेष चाल से गतिमान आवेशित कणों के चयन के लिए किया जाता है ।

2

Find the condition under which the charged particles moving with different speeds in the presence of electric and magnetic field vectors can be used to select charged particles of a particular speed.

### खण्ड स

### SECTION C

11. (a)  $589$  nm तरंगदैर्घ्य का कोई एकवर्णी प्रकाश वायु से किसी जल के पृष्ठ पर आपतित होता है । यदि जल का  $\mu = 1.33$  है, तो परावर्तित प्रकाश की तरंगदैर्घ्य, आवृत्ति और चाल ज्ञात कीजिए ।
- (b)  $1.55$  अपवर्तनांक के काँच से कोई उभयोत्तल लेंस बनाया गया है जिसके दोनों फलकों की वक्रता त्रिज्या समान हैं । यदि इस लेंस की फोकस दूरी  $20$  cm है, तो आवश्यक वक्रता त्रिज्या ज्ञात कीजिए ।

3

- (a) Monochromatic light of wavelength 589 nm is incident from air on a water surface. If  $\mu$  for water is 1.33, find the wavelength, frequency and speed of the refracted light.
- (b) A double convex lens is made of a glass of refractive index 1.55, with both faces of the same radius of curvature. Find the radius of curvature required, if the focal length is 20 cm.

12. कुण्डलियों के युगल के बीच अन्योन्य प्रेरकत्व की परिभाषा लिखिए । एक-दूसरे पर लिपटी हुई दो लम्बी समाक्ष परिनालिकाओं, जिनकी लम्बाइयाँ समान हैं, के अन्योन्य प्रेरकत्व के लिए व्यंजक व्युत्पन्न कीजिए ।

3

अथवा

किसी कुण्डली के स्वप्रेरकत्व की परिभाषा लिखिए । किसी विद्युत्-वाहक बल (emf) के स्रोत से संयोजित प्रेरक L में संचित ऊर्जा के लिए व्यंजक प्राप्त कीजिए ।

3

Define mutual inductance between a pair of coils. Derive an expression for the mutual inductance of two long coaxial solenoids of same length wound one over the other.

OR

Define self-inductance of a coil. Obtain the expression for the energy stored in an inductor L connected across a source of emf.

13. (a) किसी मीटर सेतु का कार्यकारी सिद्धान्त लिखिए ।
- (b) किसी मीटर सेतु में, आरेख में दर्शाए अनुसार, प्रतिरोध R और S के साथ दूरी  $l_1$  पर संतुलन बिन्दु प्राप्त होता है ।

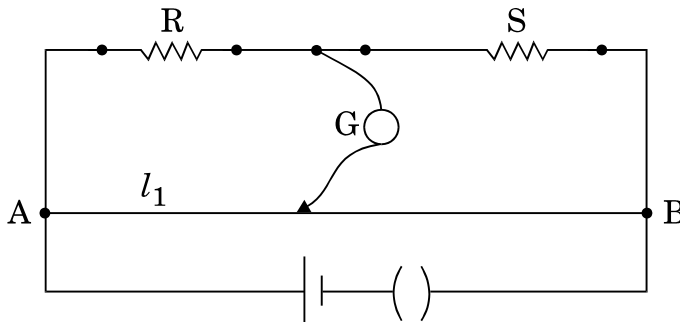

प्रतिरोध S के पार्श्व में किसी अज्ञात प्रतिरोध X को संयोजित करने पर अब संतुलन बिन्दु दूरी  $l_2$  पर प्राप्त होता है ।  $l_1$ ,  $l_2$  और S के पदों में X के लिए सूत्र प्राप्त कीजिए ।

3

- (a) Write the principle of working of a metre bridge.
- (b) In a metre bridge, the balance point is found at a distance  $l_1$  with resistances R and S as shown in the figure.

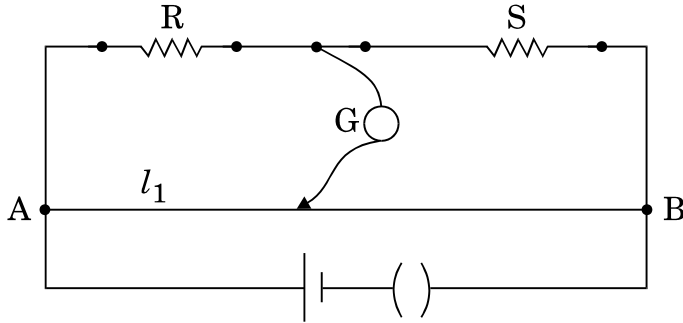

An unknown resistance X is now connected in parallel to the resistance S and the balance point is found at a distance  $l_2$ . Obtain a formula for X in terms of  $l_1$ ,  $l_2$  and S.

14. (a) उभयनिष्ठ उत्सर्जक विन्यास में n-p-n ट्रांज़िस्टर प्रवर्धक का परिपथ आरेख खींचिए ।
- (b) इस प्रवर्धक की वोल्टता लब्धि के लिए व्यंजक व्युत्पन्न कीजिए और अतः यह दर्शाइए कि निर्गत वोल्टता की कला निवेश वोल्टता के विपरीत है ।
- (a) Draw the circuit diagram of an n-p-n transistor amplifier in common emitter configuration.
- (b) Derive an expression for voltage gain of the amplifier and hence show that the output voltage is in opposite phase with the input voltage.

3



15. (a) दिए गए प्रतिरोधक के सिरो पर अनुप्रयुक्त विभवान्तर को परिवर्तित करने पर प्रति सेकण्ड उत्पन्न ऊष्मा 9 गुनी हो गई । अनुप्रयुक्त विभवान्तर में किस गुणक द्वारा परिवर्तन किया गया ?
- (b) दर्शाए गए आरेख में, किसी स्रोत के टर्मिनलों से एक ऐमीटर A और  $4 \Omega$  का एक प्रतिरोधक संयोजित किया गया है । स्रोत का आंतरिक प्रतिरोध  $2 \Omega$  और विद्युत्-वाहक बल (emf)  $12 \text{ V}$  है । वोल्टमीटर और ऐमीटर के पाठ्यांक परिकल्पित कीजिए ।

3

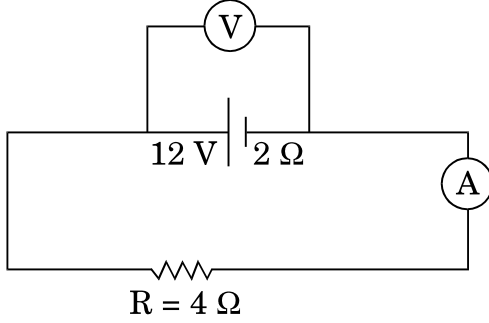

- (a) The potential difference applied across a given resistor is altered so that the heat produced per second increases by a factor of 9. By what factor does the applied potential difference change ?
- (b) In the figure shown, an ammeter A and a resistor of  $4 \Omega$  are connected to the terminals of the source. The emf of the source is  $12 \text{ V}$  having an internal resistance of  $2 \Omega$ . Calculate the voltmeter and ammeter readings.

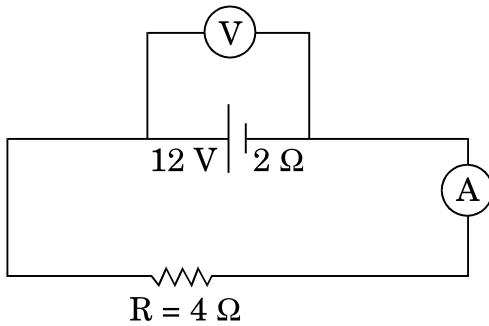

16. किसी व्यापकीकृत संचार व्यवस्था का ब्लॉक आरेख खींचिए । निम्नलिखित में प्रत्येक के कार्य लिखिए :

3

- (a) प्रेषित्र  
 (b) चैनल  
 (c) अभिग्राही

Draw a block diagram of a generalized communication system. Write the functions of each of the following :

- (a) Transmitter
- (b) Channel
- (c) Receiver

17. (a) किसी संयुक्त सूक्ष्मदर्शी द्वारा प्रतिबिम्ब बनना दर्शाने के लिए किरण आरेख खींचिए ।  
 (b) आपको निम्नलिखित तीन लेंस दिए गए हैं । किसी संयुक्त सूक्ष्मदर्शी की रचना के लिए आप इनमें से किन दो लेंसों का उपयोग नेत्रिका और अभिदृश्यक के रूप में करेंगे ?

लेंस	क्षमता (D)	द्वारक (सेमी)
L <sub>1</sub>	3	8
L <sub>2</sub>	6	1
L <sub>3</sub>	10	1

- (c) किसी सूक्ष्मदर्शी की विभेदन क्षमता को परिभाषित कीजिए तथा एक कारक लिखिए जिस पर यह निर्भर करता है ।

3

- (a) Draw a ray diagram for the formation of image by a compound microscope.  
 (b) You are given the following three lenses. Which two lenses will you use as an eyepiece and as an objective to construct a compound microscope ?

Lenses	Power (D)	Aperture (cm)
L <sub>1</sub>	3	8
L <sub>2</sub>	6	1
L <sub>3</sub>	10	1

- (c) Define resolving power of a microscope and write one factor on which it depends.



18. निम्नलिखित ग्राफ किसी प्रकाश-सुग्राही धातु के लिए प्रकाश-विद्युत् धारा का विचरण दर्शाता है :

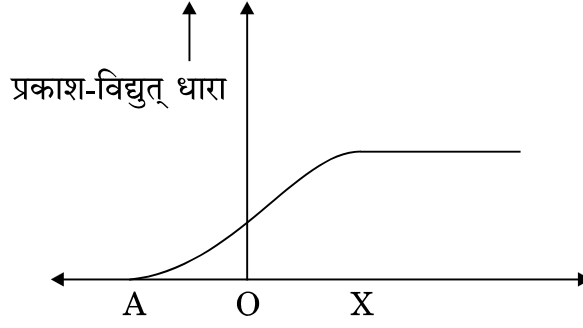

- (a) क्षैतिज अक्ष पर चर X को पहचानिए ।  
 (b) क्षैतिज अक्ष पर बिन्दु A क्या निरूपित करता है ?  
 (c) समान तीव्रता और आपतित विकिरणों की तीन विभिन्न आवृत्तियों  $\nu_1$ ,  $\nu_2$  और  $\nu_3$  ( $\nu_1 > \nu_2 > \nu_3$ ) के मानों के लिए इस ग्राफ को खींचिए ।  
 (d) समान आवृत्ति और आपतित विकिरणों की तीन विभिन्न तीव्रताओं  $I_1$ ,  $I_2$  और  $I_3$  ( $I_1 > I_2 > I_3$ ) के मानों के लिए इस ग्राफ को खींचिए ।

3

The following graph shows the variation of photocurrent for a photosensitive metal :

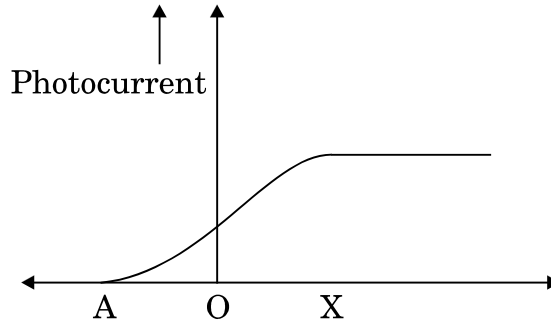

- (a) Identify the variable X on the horizontal axis.  
 (b) What does the point A on the horizontal axis represent ?  
 (c) Draw this graph for three different values of frequencies of incident radiation  $\nu_1$ ,  $\nu_2$  and  $\nu_3$  ( $\nu_1 > \nu_2 > \nu_3$ ) for same intensity.  
 (d) Draw this graph for three different values of intensities of incident radiation  $I_1$ ,  $I_2$  and  $I_3$  ( $I_1 > I_2 > I_3$ ) having same frequency.

19. दो सर्वसम समान्तर पट्टिका संधारित्र A और B किसी V वोल्ट की बैटरी से संयोजित हैं और स्विच S बन्द है। स्विच को अब खोल दिया जाता है और इन संधारित्रों की पट्टिकाओं के रिक्त स्थान के बीच परावैद्युतांक K का कोई परावैद्युत भर दिया जाता है। इन दोनों संधारित्रों में परावैद्युत भरने से पूर्व और परावैद्युत भरने के पश्चात् संचित कुल स्थिर-वैद्युत ऊर्जा का अनुपात ज्ञात कीजिए।

3

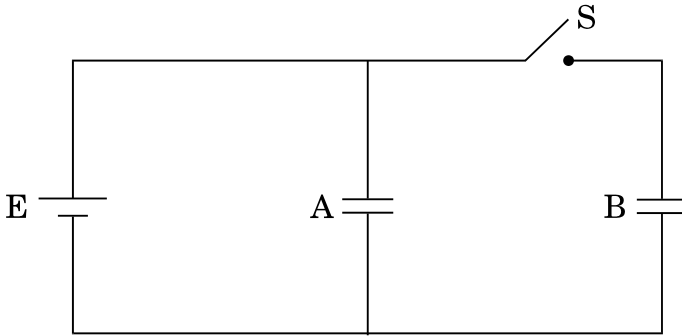

Two identical parallel plate capacitors A and B are connected to a battery of V volts with the switch S closed. The switch is now opened and the free space between the plates of the capacitors is filled with a dielectric of dielectric constant K. Find the ratio of the total electrostatic energy stored in both capacitors before and after the introduction of the dielectric.

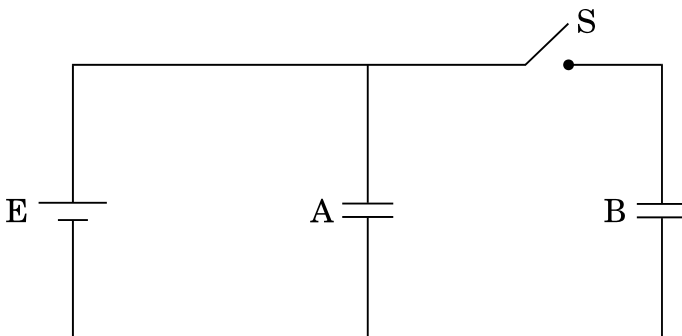

20. (a) आयाम मॉडुलन किस प्रकार किया जाता है ?  
 (b) किसी आयाम मॉडुलित तरंग के दो पार्श्व बैंडों की आवृत्तियाँ क्रमशः 640 kHz और 660 kHz हैं । वाहक और मॉडुलक सिग्नल की आवृत्तियाँ ज्ञात कीजिए । आयाम मॉडुलन के लिए आवश्यक बैंड चौड़ाई क्या है ?

3

- (a) How is amplitude modulation achieved ?  
 (b) The frequencies of two side bands in an AM wave are 640 kHz and 660 kHz respectively. Find the frequencies of carrier and modulating signal. What is the bandwidth required for amplitude modulation ?

21. (a) निम्नलिखित आरेख में 'S' कोई अर्धचालक है । जब S को तप्त किया जा रहा है, तो ऐमीटर A के पाठ्यांक को नियत रखने के लिए आप R के मान को बढ़ाएँगे अथवा घटाएँगे ? अपने उत्तर के लिए कारण दीजिए ।

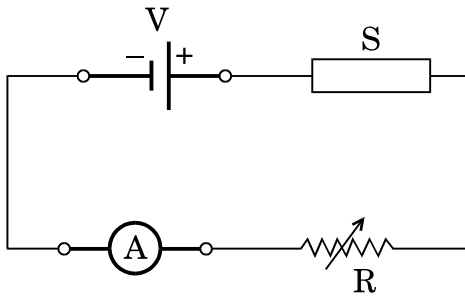

- (b) किसी प्रकाश-विद्युत् डायोड का परिपथ आरेख खींचिए और इसकी क्रियाविधि की व्याख्या कीजिए । इसका I – V अभिलाक्षणिक खींचिए ।

3

- (a) In the following diagram 'S' is a semiconductor. Would you increase or decrease the value of R to keep the reading of the ammeter A constant when S is heated ? Give reason for your answer.

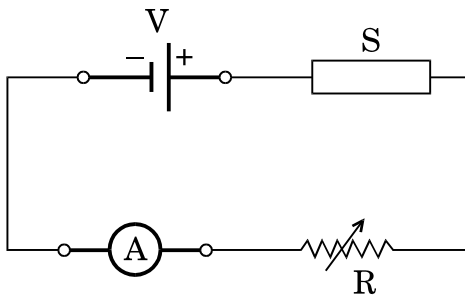

- (b) Draw the circuit diagram of a photodiode and explain its working. Draw its I – V characteristics.



22. (a) बायो – सावर्ट नियम लिखिए और इस नियम को सदिश रूप में व्यक्त कीजिए ।

(b) त्रिज्या R की दो सर्वसम वृत्ताकार कुण्डलियाँ P और Q, जिनसे क्रमशः 1 A और  $\sqrt{3}$  A धाराएँ प्रवाहित हो रही हैं, XY और YZ तलों में एक-दूसरे के लम्बवत् और संकेन्द्री रखी हैं । इन कुण्डलियों के केन्द्र पर नेट चुम्बकीय क्षेत्र का परिमाण और दिशा ज्ञात कीजिए ।

3

(a) State Biot – Savart law and express this law in the vector form.

(b) Two identical circular coils, P and Q each of radius R, carrying currents 1 A and  $\sqrt{3}$  A respectively, are placed concentrically and perpendicular to each other lying in the XY and YZ planes. Find the magnitude and direction of the net magnetic field at the centre of the coils.

### खण्ड द

### SECTION D

23. आशा की माताजी ने चेर्नोबिल में हुई दुर्घटना के विषय में एक लेख समाचार-पत्र में पढ़ा । वह इस लेख के विषय में कुछ अधिक नहीं समझ पायीं और इस लेख से सम्बन्धित कुछ प्रश्न आशा से पूछे । उसने जो कुछ कक्षा XII में भौतिकी में सीखा था, उसी के आधार पर अपनी माताजी के प्रश्नों के उत्तर देने का प्रयास किया ।

(a) चेर्नोबिल में जहाँ दुर्घटना हुई वहाँ पर क्या प्रतिष्ठापित था ? आपके विचार से इस दुर्घटना का क्या कारण था ?

(b) चेर्नोबिल पर प्रतिष्ठापन में ऊर्जा मुक्त होने की प्रक्रिया की व्याख्या कीजिए ।

(c) आपके विचार से आशा और उसकी माताजी द्वारा प्रदर्शित मूल्य क्या थे ?

4



Asha's mother read an article in the newspaper about a disaster that took place at Chernobyl. She could not understand much from the article and asked a few questions from Asha regarding the article. Asha tried to answer her mother's questions based on what she learnt in Class XII Physics.

- What was the installation at Chernobyl where the disaster took place ? What, according to you, was the cause of this disaster ?
- Explain the process of release of energy in the installation at Chernobyl.
- What, according to you, were the values displayed by Asha and her mother ?

### खण्ड य

### SECTION E

24. किसी युक्ति 'X' को किसी ac स्रोत  $V = V_0 \sin \omega t$  से संयोजित किया गया है । निम्नलिखित ग्राफ में दिखाए गए एक चक्र में वोल्टता, धारा और शक्ति के विचरण को दर्शाया गया है :

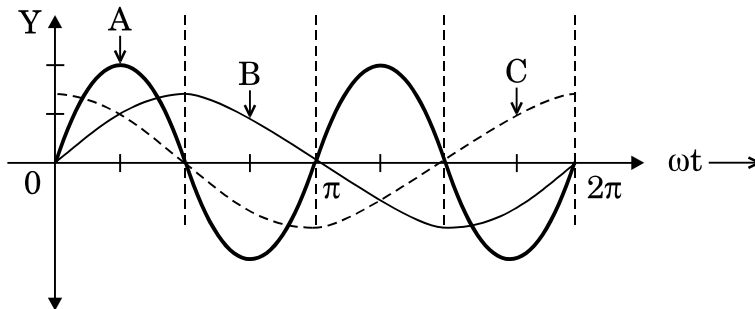

- युक्ति 'X' को पहचानिए ।
- इन वक्रों A, B और C में कौन वोल्टता, धारा और उपभुक्त शक्ति को परिपथ में निरूपित करते हैं ? अपने उत्तर की पुष्टि कीजिए ।
- ac स्रोत की आवृत्ति के साथ इसकी प्रतिबाधा किस प्रकार विचरण करती है ? ग्राफ़ द्वारा दर्शाइए ।
- परिपथ में धारा और ac वोल्टता से इसके कला-सम्बन्ध के लिए व्यंजक प्राप्त कीजिए ।

5

अथवा

- (a) ac जनित्र का नामांकित आरेख खींचिए । चुम्बकीय क्षेत्र  $\vec{B}$  की उपस्थिति में घूर्णन करती हुई  $N$  फेरों की किसी कुण्डली, जिसमें प्रत्येक की अनुप्रस्थ-काट का क्षेत्रफल  $A$  है, में प्रेरित विद्युत्-वाहक बल (emf) के लिए व्यंजक प्राप्त कीजिए ।
- (b) पूर्व से पश्चिम की ओर विस्तारित  $10 \text{ m}$  लम्बी कोई क्षैतिज चालक छड़,  $5.0 \text{ ms}^{-1}$  की चाल से,  $0.3 \times 10^{-4} \text{ Wb m}^{-2}$  के पृथ्वी के चुम्बकीय क्षेत्र के क्षैतिज घटक के समकोण पर गिर रही है । इस छड़ में प्रेरित विद्युत्-वाहक बल (emf) का तात्क्षणिक मान ज्ञात कीजिए ।

5

A device 'X' is connected to an ac source  $V = V_0 \sin \omega t$ . The variation of voltage, current and power in one cycle is shown in the following graph :

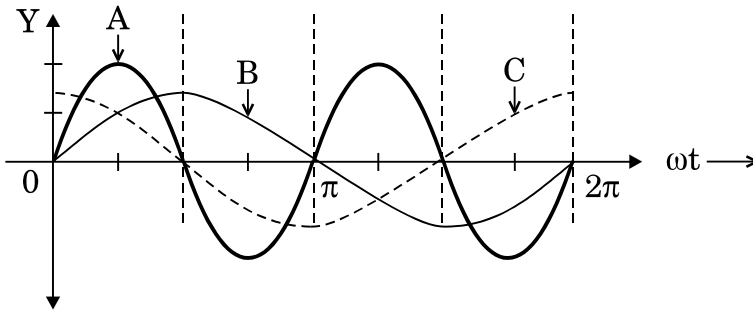

- (a) Identify the device 'X'.
- (b) Which of the curves A, B and C represent the voltage, current and the power consumed in the circuit ? Justify your answer.
- (c) How does its impedance vary with frequency of the ac source ? Show graphically.
- (d) Obtain an expression for the current in the circuit and its phase relation with ac voltage.

OR





- (a) Draw a labelled diagram of an ac generator. Obtain the expression for the emf induced in the rotating coil of  $N$  turns each of cross-sectional area  $A$ , in the presence of a magnetic field  $\vec{B}$ .
- (b) A horizontal conducting rod 10 m long extending from east to west is falling with a speed  $5.0 \text{ ms}^{-1}$  at right angles to the horizontal component of the Earth's magnetic field,  $0.3 \times 10^{-4} \text{ Wb m}^{-2}$ . Find the instantaneous value of the emf induced in the rod.

25. (a) तरंगाग्र की परिभाषा लिखिए। हाइगेन्स सिद्धान्त का उपयोग करके अपवर्तन के नियम सत्यापित कीजिए।
- (b) प्रकाश के प्रकीर्णन की प्रक्रिया द्वारा रैखिकतः ध्रुवित प्रकाश किस प्रकार प्राप्त किया जाता है? जब काँच का अपवर्तनांक = 1.5 है, तो वायु – काँच अंतरापृष्ठ के लिए ब्रूस्टर कोण ज्ञात कीजिए।

5

अथवा

- (a) सम्पर्क में रखे दो पतले उत्तल लेंसों के संयोजन द्वारा प्रतिबिम्ब बनना दर्शाने के लिए किरण आरेख खींचिए। लेंसों की फोकस दूरी के पदों में इस संयोजन की क्षमता के लिए व्यंजक प्राप्त कीजिए।
- (b) वायु से काँच के समबाहु प्रिज़्म से गुज़रती हुई कोई प्रकाश किरण उस समय न्यूनतम विचलित होती है, जब आपतन कोण का मान प्रिज़्म कोण के मान का  $\frac{3}{4}$  होता है। प्रिज़्म में प्रकाश की चाल परिकलित कीजिए।
- (a) Define wavefront. Use Huygens' principle to verify the laws of refraction.
- (b) How is linearly polarised light obtained by the process of scattering of light? Find the Brewster angle for air – glass interface, when the refractive index of glass = 1.5.

5

OR



- (a) Draw a ray diagram to show the image formation by a combination of two thin convex lenses in contact. Obtain the expression for the power of this combination in terms of the focal lengths of the lenses.
- (b) A ray of light passing from air through an equilateral glass prism undergoes minimum deviation when the angle of incidence is  $\frac{3}{4}$ th of the angle of prism. Calculate the speed of light in the prism.

26. (a) लम्बाई '2a' के किसी द्विध्रुव के कारण उसकी अक्षीय रेखा पर द्विध्रुव के केन्द्र से r दूरी पर स्थित किसी बिन्दु पर विद्युत्-क्षेत्र E के लिए व्यंजक व्युत्पन्न कीजिए ।
- (b)  $r \gg a$  के लिए E और r के बीच ग्राफ़ खींचिए ।
- (c) यदि यह द्विध्रुव किसी एकसमान बाह्य विद्युत्-क्षेत्र  $E_0$  में स्थित हो, तो इस द्विध्रुव की स्थायी और अस्थायी साम्य की स्थिति का आरेखीय निरूपण कीजिए और दोनों ही प्रकरणों में इस द्विध्रुव पर कार्यरत बल-आघूर्णों के लिए व्यंजक लिखिए ।

5

### अथवा

- (a) गाउस प्रमेय का उपयोग करके पृष्ठीय आवेश घनत्व  $\sigma$  की किसी एकसमान आवेशित अनन्तः बड़ी समतल पतली शीट के कारण विद्युत्-क्षेत्र ज्ञात कीजिए ।
- (b) किसी अनन्तः बड़ी समतल पतली शीट का एकसमान पृष्ठीय आवेश घनत्व  $+\sigma$  है । किसी बिन्दु आवेश q को अनन्त से इस आवेशित समतल शीट के सम्मुख दूरी r पर स्थित किसी बिन्दु तक लाने में किए गए कार्य के लिए व्यंजक प्राप्त कीजिए ।

5



- (a) Derive an expression for the electric field  $E$  due to a dipole of length ' $2a$ ' at a point distant  $r$  from the centre of the dipole on the axial line.
- (b) Draw a graph of  $E$  versus  $r$  for  $r \gg a$ .
- (c) If this dipole were kept in a uniform external electric field  $E_0$ , diagrammatically represent the position of the dipole in stable and unstable equilibrium and write the expressions for the torque acting on the dipole in both the cases.

**OR**

- (a) Use Gauss's theorem to find the electric field due to a uniformly charged infinitely large plane thin sheet with surface charge density  $\sigma$ .
- (b) An infinitely large thin plane sheet has a uniform surface charge density  $+\sigma$ . Obtain the expression for the amount of work done in bringing a point charge  $q$  from infinity to a point, distant  $r$ , in front of the charged plane sheet.



## MARKING SCHEME

Q. No.	Expected Answer/ Value Points	Marks	Total Marks
<b>Section A</b>			
Q1	i. Decreases ii. $n_{\text{Violet}} > n_{\text{Red}}$ (Also accept if the student writes $\lambda_V < \lambda_R$ )	$\frac{1}{2}$  $\frac{1}{2}$	<b>1</b>
Q2	Photoelectric Effect (/Raman Effect/ Compton Effect)	<b>1</b>	<b>1</b>
Q3	Clockwise in loop 1 Anticlockwise in loop 2	$\frac{1}{2}$  $\frac{1}{2}$	<b>1</b>
Q4	$\vec{E}$ along y- axis and $\vec{B}$ along z-axis ( <b>Alternatively</b> : $\vec{E}$ along z-axis and $\vec{B}$ along y-axis)	$\frac{1}{2} + \frac{1}{2}$	<b>1</b>
Q5	i. Nichrome ii. $R_{\text{Ni}} > R_{\text{Cu}}$ (or Resistivity <sub>Ni</sub> > Resistivity <sub>Cu</sub> )	$\frac{1}{2}$  $\frac{1}{2}$	<b>1</b>
<b>SECTION B</b>			
Q6	<div style="border: 1px solid black; padding: 5px; margin-bottom: 10px;">           a) Two properties for making permanent magnet    <math>\frac{1}{2} + \frac{1}{2}</math>            b) Two properties for making an electromagnet    <math>\frac{1}{2} + \frac{1}{2}</math> </div> a) For making permanent magnet: (i) High retentivity (ii) High coercivity (iii) High permeability (Any two)	$\frac{1}{2} + \frac{1}{2}$	

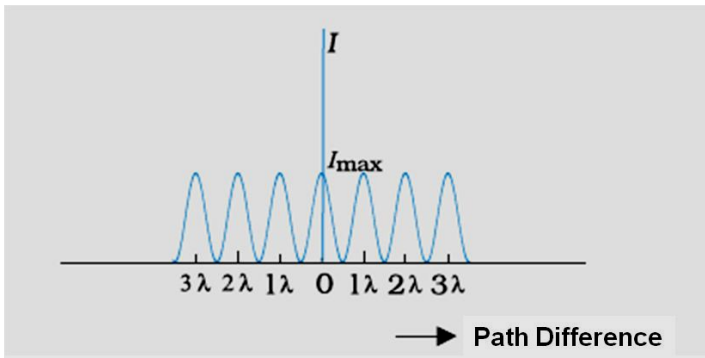
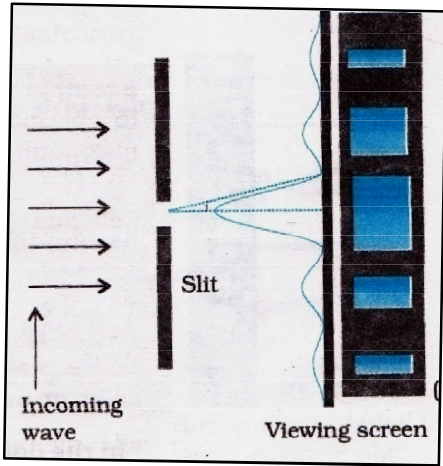

	<p>b) For making electromagnet:</p> <ul style="list-style-type: none"> <li>(i) High permeability</li> <li>(ii) Low retentivity</li> <li>(iii) Low coercivity</li> </ul> <p>(Any two)</p>	$\frac{1}{2} + \frac{1}{2}$	<b>2</b>
--	--	-----------------------------	----------

<b>Q7</b>	<table style="width: 100%; border-collapse: collapse;"> <tr> <td style="width: 70%;">Interference pattern</td> <td style="width: 30%; text-align: center;">1/2</td> </tr> <tr> <td>Diffraction pattern</td> <td style="text-align: center;">1/2</td> </tr> <tr> <td>Two Differences</td> <td style="text-align: center;">1/2 + 1/2</td> </tr> </table>	Interference pattern	1/2	Diffraction pattern	1/2	Two Differences	1/2 + 1/2	$\frac{1}{2}$	
	Interference pattern	1/2							
Diffraction pattern	1/2								
Two Differences	1/2 + 1/2								
  	$\frac{1}{2}$								

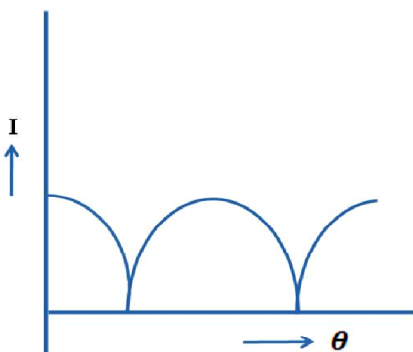
	<p><b>Differences</b></p> <table border="1" style="width: 100%; border-collapse: collapse;"> <thead> <tr> <th style="width: 50%; text-align: center;">Interference</th> <th style="width: 50%; text-align: center;">Diffraction</th> </tr> </thead> <tbody> <tr> <td>All maxima have equal intensity</td> <td>Maxima have different (/rapidly decreasing) intensity</td> </tr> <tr> <td>All fringes have equal width.</td> <td>Different (/changing) width.</td> </tr> <tr> <td>Superposition of two wavefronts</td> <td>Superposition of wavelets from the same wavefront</td> </tr> </tbody> </table> <p style="text-align: center;">(Any two)</p> <p style="text-align: center;"><b>OR</b></p> <table border="1" style="width: 100%; border-collapse: collapse;"> <tr> <td style="width: 80%;">Expression for intensity of polarized beam</td> <td style="width: 20%; text-align: center;">1</td> </tr> <tr> <td>Plot of intensity variation with angle</td> <td style="text-align: center;">1</td> </tr> </table> <p>Intensity is <math>\frac{I_0}{2} \cos^2 \theta</math> (if <math>I_0</math> is the intensity of unpolarised light.)          Intensity is <math>I \cos^2 \theta</math> (if <math>I</math> is the intensity of polarized light.)          (Award <math>\frac{1}{2}</math> mark if the student writes the expression as <math>I_0 \cos^2 \theta</math>)</p> <div style="text-align: center;">  </div>	Interference	Diffraction	All maxima have equal intensity	Maxima have different (/rapidly decreasing) intensity	All fringes have equal width.	Different (/changing) width.	Superposition of two wavefronts	Superposition of wavelets from the same wavefront	Expression for intensity of polarized beam	1	Plot of intensity variation with angle	1	<p><math>\frac{1}{2} + \frac{1}{2}</math></p> <p><b>2</b></p> <p><b>1</b></p> <p><b>1</b></p> <p><b>2</b></p>	
Interference	Diffraction														
All maxima have equal intensity	Maxima have different (/rapidly decreasing) intensity														
All fringes have equal width.	Different (/changing) width.														
Superposition of two wavefronts	Superposition of wavelets from the same wavefront														
Expression for intensity of polarized beam	1														
Plot of intensity variation with angle	1														
<p>Q8</p>	<table border="1" style="width: 100%; border-collapse: collapse;"> <tr> <td style="width: 80%;">a) Reason for no flow of current</td> <td style="width: 20%; text-align: center;">1</td> </tr> <tr> <td>b) Reason for momentary current</td> <td style="text-align: center;">1</td> </tr> </table> <p>In the steady state, the displacement current and hence the conduction current, is zero as <math> \vec{E} </math>, between the plates, is constant.</p> <p>During charging / discharging, the displacement current and hence the conduction current is non zero as <math> \vec{E} </math>, between the plates, is changing with time.</p>	a) Reason for no flow of current	1	b) Reason for momentary current	1	<p><b>1</b></p> <p><b>1</b></p>									
a) Reason for no flow of current	1														
b) Reason for momentary current	1														

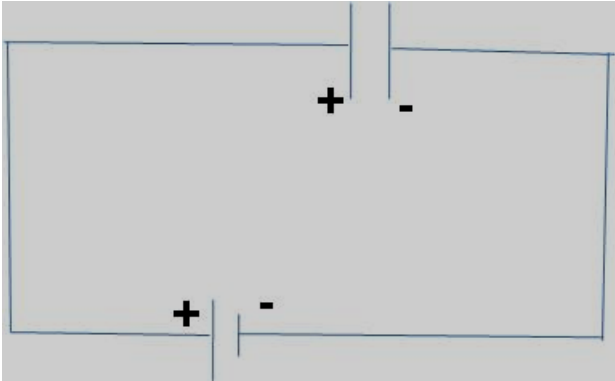
	<p><u>Alternatively</u></p> <p>i) In the steady state no current flows because, we have two sources (battery and fully charged capacitor) of 'equal potential' connected in opposition.</p> <p>ii) During charging /discharging there is a momentary flow of current as the 'potentials' of the two 'sources' are not equal to each other.</p>  <p><u>Alternatively,</u></p> <p style="text-align: center;">Capacitive impedance = <math>\frac{1}{\omega C}</math></p> <p>iii) During steady state: <math>\omega = 0</math>  <math>\therefore X_c \rightarrow \infty</math>  Hence current is zero.</p> <p>iv) During charging /discharging : <math>\omega \neq 0</math>  <math>\therefore X_c</math> is finite.  Hence current can flow.</p>	<p style="text-align: center;">1</p> <p style="text-align: center;">1</p> <p style="text-align: center;"><math>\frac{1}{2}</math></p> <p style="text-align: center;"><math>\frac{1}{2}</math></p> <p style="text-align: center;"><math>\frac{1}{2}</math></p> <p style="text-align: center;"><math>\frac{1}{2}</math></p>	<p style="text-align: center;">2</p>								
<p>Q9</p>	<table border="1" style="width: 100%;"> <tr> <td>a) Calculation of energy difference</td> <td style="text-align: right;"><math>\frac{1}{2}</math></td> </tr> <tr> <td>b) Formula</td> <td style="text-align: right;"><math>\frac{1}{2}</math></td> </tr> <tr> <td>c) Calculation of wavelength</td> <td style="text-align: right;"><math>\frac{1}{2}</math></td> </tr> <tr> <td>d) Name of the series of spectral lines</td> <td style="text-align: right;"><math>\frac{1}{2}</math></td> </tr> </table>	a) Calculation of energy difference	$\frac{1}{2}$	b) Formula	$\frac{1}{2}$	c) Calculation of wavelength	$\frac{1}{2}$	d) Name of the series of spectral lines	$\frac{1}{2}$		
a) Calculation of energy difference	$\frac{1}{2}$										
b) Formula	$\frac{1}{2}$										
c) Calculation of wavelength	$\frac{1}{2}$										
d) Name of the series of spectral lines	$\frac{1}{2}$										

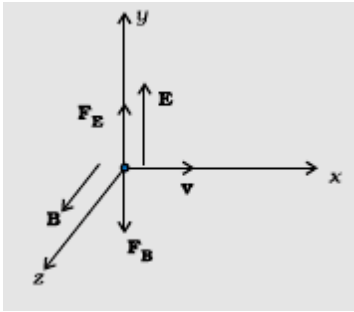
	<p>Energy difference = <math>3.4 \text{ eV} - 1.51 \text{ eV} = 1.89 \text{ eV} = 3.024 \times 10^{-19} \text{ J}</math></p> <p>Energy = <math>\frac{hc}{\lambda} = 3.024 \times 10^{-19} \text{ J}</math></p> <p>Wavelength = <math>6.57 \times 10^{-7} \text{ m}</math></p> <p>Series is Balmer series</p>	<p><math>\frac{1}{2}</math></p> <p><math>\frac{1}{2}</math></p> <p><math>\frac{1}{2}</math></p> <p><math>\frac{1}{2}</math></p>	<p><b>2</b></p>
<p>Q10</p>	<div style="border: 1px solid black; padding: 5px; margin-bottom: 10px;"> <p>Condition</p> <p>i. For directions of <math>\vec{E}, \vec{B}, \vec{v}</math> <span style="float: right;">1</span></p> <p>ii. For magnitudes of <math>\vec{E}, \vec{B}, \vec{v}</math> <span style="float: right;">1</span></p> </div> <p>(i) The velocity <math>\vec{v}</math>, of the charged particles, and the <math>\vec{E}</math> and <math>\vec{B}</math> vectors, should be mutually perpendicular. Also the forces on <math>q</math>, due to <math>\vec{E}</math> and <math>\vec{B}</math>, must be oppositely directed. (Also accept if the student draws a diagram to show the directions.)</p> <div style="text-align: center; margin: 10px 0;">  </div> <p>(ii) <math>qE = qvB</math> or <math>v = \frac{E}{B}</math></p> <p>[Alternatively, The student may write: Force due to electric field = <math>q\vec{E}</math> Force due to magnetic field = <math>q(\vec{v} \times \vec{B})</math> The required condition is <math>q\vec{E} = -q(\vec{v} \times \vec{B})</math> [or <math>\vec{E} = -(\vec{v} \times \vec{B}) = (\vec{B} \times \vec{v})</math>]</p> <p>(Note: Award 1 mark only if the student just writes: “The forces, on the charged particle, due to the electric and magnetic fields, must be equal and opposite to each other”)]</p>	<p><math>\frac{1}{2}</math></p> <p><math>\frac{1}{2}</math></p> <p><math>\frac{1}{2}</math></p> <p><math>\frac{1}{2}</math></p> <p><math>\frac{1}{2}</math></p> <p><math>\frac{1}{2}</math></p> <p><math>\frac{1}{2}</math></p>	<p><b>2</b></p>





SECTION C									
Q11	<table border="1" data-bbox="249 262 1033 453"> <tr> <td>a. Calculation of wavelength, frequency and speed</td> <td><math>\frac{1}{2} + \frac{1}{2} + \frac{1}{2}</math></td> </tr> <tr> <td>b. Lens Maker's Formula</td> <td><math>\frac{1}{2}</math></td> </tr> <tr> <td>Calculation of <math>R</math></td> <td>1</td> </tr> </table> <p>a) <math>\lambda = \frac{589 \text{ nm}}{1.33} = 442.8 \text{ nm}</math></p> <p>Frequency <math>\nu = \frac{3 \times 10^8 \text{ ms}^{-1}}{589 \text{ nm}} = 5.09 \times 10^{12} \text{ Hz}</math></p> <p>Speed <math>v = \frac{3 \times 10^8}{1.33} \text{ m/s} = 2.25 \times 10^8 \text{ m/s}</math></p> <p>b) <math>\frac{1}{f} = \left[ \frac{\mu_2}{\mu_1} - 1 \right] \left[ \frac{1}{R_1} - \frac{1}{R_2} \right]</math></p> <p><math>\therefore \frac{1}{20} = \left[ \frac{1.55}{1} - 1 \right] \frac{2}{R}</math></p> <p><math>\therefore R = (20 \times 1.10) \text{ cm} = 22 \text{ cm}</math></p>	a. Calculation of wavelength, frequency and speed	$\frac{1}{2} + \frac{1}{2} + \frac{1}{2}$	b. Lens Maker's Formula	$\frac{1}{2}$	Calculation of $R$	1	$\frac{1}{2}$	
a. Calculation of wavelength, frequency and speed	$\frac{1}{2} + \frac{1}{2} + \frac{1}{2}$								
b. Lens Maker's Formula	$\frac{1}{2}$								
Calculation of $R$	1								
Q12	<table border="1" data-bbox="249 1124 1007 1260"> <tr> <td>Definition of mutual inductance</td> <td>1</td> </tr> <tr> <td>Derivation of mutual inductance for two long solenoids</td> <td>2</td> </tr> </table> <p>(i) Mutual inductance is numerically equal to the induced emf in the secondary coil when the current in the primary coil changes by unity.</p> <p><u>Alternatively:</u> Mutual inductance is numerically equal to the magnetic flux linked with one coil/secondary coil when unit current flows through the other coil /primary coil.</p>	Definition of mutual inductance	1	Derivation of mutual inductance for two long solenoids	2	1	3		
Definition of mutual inductance	1								
Derivation of mutual inductance for two long solenoids	2								



(ii)

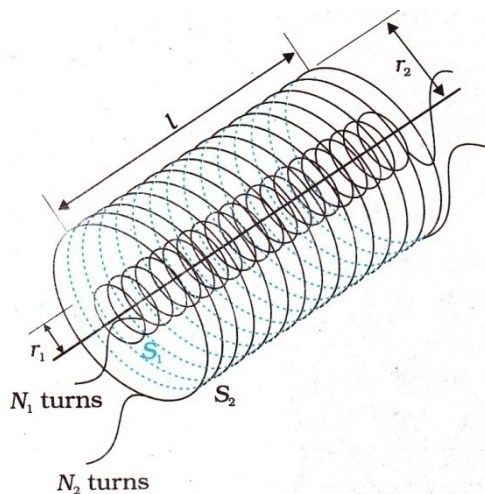

Let a current,  $i_2$ , flow in the secondary coil

$$\therefore B_2 = \frac{\mu_0 N_2 i_2}{l}$$

$\therefore$  Flux linked with the primary coil

$$= N_1 A_1 B_2 = \frac{\mu_0 N_2 N_1 A_1 i_2}{l} = M_{12} i_2$$

Hence,  $M_{12} = \frac{\mu_0 N_2 N_1 A_1}{l} = \mu_0 n_2 n_1 A_1 l$  ( $n_1 = \frac{N_1}{l}; n_2 = \frac{N_2}{l}$ )

**OR**

Definition of self inductance	1
Expression for energy stored	2

(i) Self inductance, of a coil, is numerically equal to the emf induced in that coil when the current in it changes at a unit rate.

(Alternatively: The self inductance of a coil equals the flux linked with it when a unit current flows through it.)

1/2

1/2

1/2

1/2

3

1

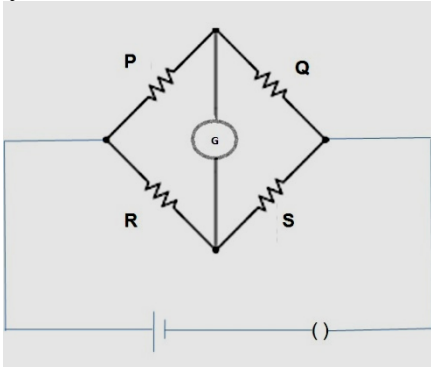
	<p>(ii) The work done against back /induced emf is stored as magnetic potential energy.</p> <p>The rate of work done, when a current <math>i</math> is passing through the coil, is</p> $\frac{dW}{dt} =  \varepsilon i = \left(L \frac{di}{dt}\right) i$ $\therefore W = \int dW = \int_0^I Lidi$ $= \frac{1}{2} Li^2$	<p>1/2</p> <p>1/2</p> <p>1/2</p> <p>1/2</p>	<p><b>3</b></p>				
<p>Q13</p>	<table border="1" style="width: 100%; border-collapse: collapse;"> <tr> <td style="padding: 5px;">a) Principle of meter bridge</td> <td style="text-align: right; padding: 5px;">1</td> </tr> <tr> <td style="padding: 5px;">b) Relation between <math>l_1, l_2</math>, and <math>S</math></td> <td style="text-align: right; padding: 5px;">2</td> </tr> </table> <p>a) The principle of working of a meter bridge is same as that of a balanced Wheatstone bridge.</p> <p>(Alternatively:</p> <div style="text-align: center;">  </div> <p style="text-align: center;">When <math>i_g=0</math>, then <math>\frac{P}{Q} = \frac{R}{S}</math>)</p> <p>b) <math>\frac{R}{S} = \frac{l_1}{100-l_1}</math></p> <p>When <math>X</math> is connected in parallel:</p> $\frac{R}{\left(\frac{XS}{X+S}\right)} = \frac{l_2}{100-l_2}$ <p>On solving, we get <math>X = \frac{l_1 S (100-l_2)}{100(l_2-l_1)}</math></p>	a) Principle of meter bridge	1	b) Relation between $l_1, l_2$ , and $S$	2	<p>1</p> <p>1/2</p> <p>1/2</p> <p>1</p>	<p><b>3</b></p>
a) Principle of meter bridge	1						
b) Relation between $l_1, l_2$ , and $S$	2						

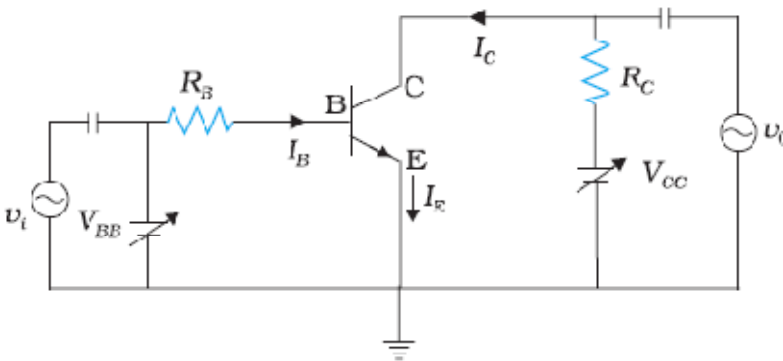
<p>Q14</p>	<div style="border: 1px solid black; padding: 5px; margin-bottom: 10px;"> <p>Transistor amplifier circuit diagram                      1</p> <p>Derivation of voltage gain                                      1 ½</p> <p>Explanation of phase reversal                                  ½</p> </div>  <p>Change in the input voltage: <math>\Delta V_{BE} = I_B r_i</math>                                      ½</p> <p>Change in the output voltage: <math>\Delta V_{CE} = I_C R_C</math>                                      ½</p> <p>Voltage gain= Output voltage/Input voltage <math>A_V = -\frac{\beta R_C}{r_i}</math>                                      ½</p> <p>Negative sign indicates, phase difference is <math>180^\circ</math>                                      ½</p> <p>(Alternatively, There is a phase reversal)</p>	<p style="text-align: center;"><b>1</b></p>	<p style="text-align: center;"><b>3</b></p>
<p>Q15</p>	<div style="border: 1px solid black; padding: 5px; margin-bottom: 10px;"> <p>a) The factor by which the potential difference changes                      1</p> <p>b) Voltmeter reading                                      1</p> <p>    Ammeter Reading                                      1</p> </div> <p>a) <math>H = \frac{V^2}{R}</math>  <math>\therefore V</math> increases by a factor of <math>\sqrt{9} = 3</math>                                      ½</p> <p>b) Ammeter Reading <math>I = \frac{V}{R+r}</math>                                      ½</p> <p style="text-align: center;"><math>= \frac{12}{4+2} \text{ A} = 2\text{ A}</math>                                      ½</p>	<p style="text-align: center;">½</p> <p style="text-align: center;">½</p> <p style="text-align: center;">½</p> <p style="text-align: center;">½</p>	

	<p>Voltmeter Reading <math>V = E - Ir</math></p> <p><math>= [12 - (2 \times 2)] V = 8V</math></p> <p>(Alternatively, <math>V = iR = 2 \times 4V = 8V</math>)</p>	<p>1/2</p> <p>1/2</p>	<p><b>3</b></p>
<p>Q16</p>	<div data-bbox="224 433 1075 566" style="border: 1px solid black; padding: 5px;"> <p>Diagram of generalized communication system 1½</p> <p>Function of (a) transmitter (b) channel (c) receiver ½+ ½ + ½</p> </div> <div data-bbox="232 655 1037 929" style="text-align: center;"> </div> <p style="text-align: center;">-----</p> <p>[Also accept the following diagram</p> <div data-bbox="235 1050 1005 1171" style="text-align: center;"> </div> <p>(a) Transmitter: A transmitter processes the incoming message signal so as to make it suitable for transmission through a channel and subsequent reception. ½</p> <p>(b) Channel: It carries the message signal from a transmitter to a receiver. ½</p> <p>(c) Receiver: A receiver extracts the desired message signals from the received signals at the channel output. ½</p>	<p>1 ½</p> <p>½</p> <p>½</p> <p>½</p>	<p><b>3</b></p>

Q17

a) Ray diagram for compound microscope	1
b) Identification of objective and eye piece	1
c) Resolving power of microscope	1/2
d) One factor affecting the resolving power	1/2

a) Ray Diagram for compound microscope

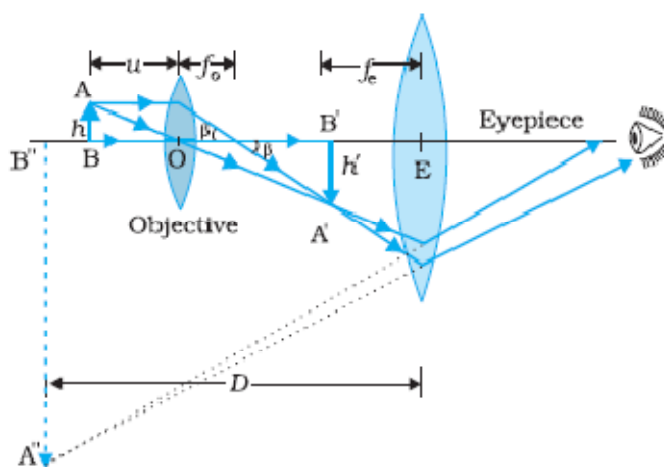

1

b) Objective: Lens  $L_3$   
 Eye Piece: Lens  $L_2$

1/2

1/2

c)  $R_p = \frac{2\mu \sin \beta}{1.22\lambda}$

1/2

d) Any one factor

1/2

1. It depends on the wavelength of the light used.
2. Semi angle of cone of incident light.
3. Aperture of the objective
4. Refractive index of the medium.

Q18

- |  |     |
|--|-----|
| (a) Identification of X                    | 1/2 |
| (b) Identification of point A              | 1/2 |
| (c) Graph for three different frequencies  | 1   |
| (d) Graph for three different intensities. | 1   |

a) X is collector plate potential.

1/2

b) A is stopping potential.

1/2

c) Graph for different frequencies

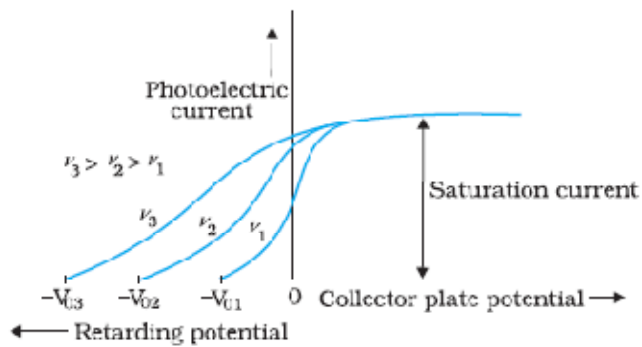

1

d) Graph for three different Intensities

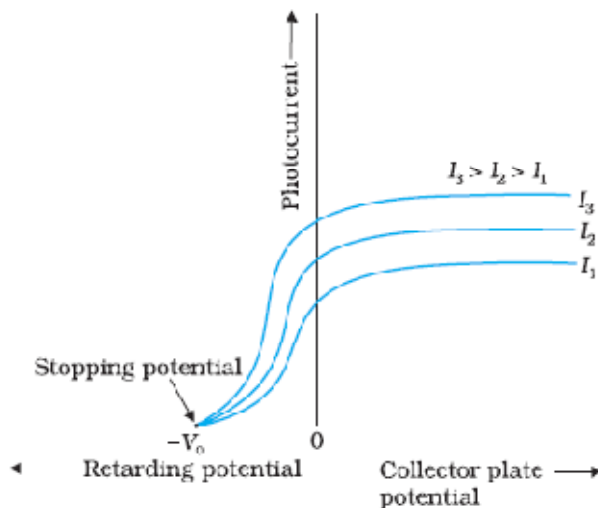

1



Q19	<table border="1" style="width: 100%; border-collapse: collapse;"> <tbody> <tr> <td style="padding: 2px;">Formula for energy stored</td> <td style="text-align: right; padding: 2px;"><math>\frac{1}{2}</math></td> </tr> <tr> <td style="padding: 2px;">Energy stored before</td> <td style="text-align: right; padding: 2px;">1</td> </tr> <tr> <td style="padding: 2px;">Energy stored after</td> <td style="text-align: right; padding: 2px;">1</td> </tr> <tr> <td style="padding: 2px;">Ratio</td> <td style="text-align: right; padding: 2px;"><math>\frac{1}{2}</math></td> </tr> </tbody> </table> <p style="padding: 10px 0 0 20px;">Energy stored = <math>\frac{1}{2} CV^2 (= \frac{1}{2} \frac{Q^2}{C})</math></p> <p style="padding: 10px 0 0 20px;">Net capacitance with switch S closed = <math>C + C = 2C</math></p> <p style="padding: 10px 0 0 20px;"><math>\therefore</math> Energy stored = <math>\frac{1}{2} \times 2C \times V^2 = CV^2</math></p> <p style="padding: 10px 0 0 20px;">After the switch S is opened, capacitance of each capacitor = <math>KC</math></p> <p style="padding: 10px 0 0 20px;"><math>\therefore</math> Energy stored in capacitor A = <math>\frac{1}{2} KCV^2</math></p> <p style="padding: 10px 0 0 20px;">For capacitor B,</p> <p style="padding: 10px 0 0 20px;">Energy stored = <math>\frac{1}{2} \frac{Q^2}{KC} = \frac{1}{2} \frac{C^2 V^2}{KC} = \frac{1}{2} \frac{CV^2}{K}</math></p> <p style="padding: 10px 0 0 20px;"><math>\therefore</math> Total Energy stored = <math>\frac{1}{2} KCV^2 + \frac{1}{2} \frac{CV^2}{K} = \frac{1}{2} CV^2 \left( K + \frac{1}{K} \right)</math></p> <p style="padding: 10px 0 0 20px;"><math>= \frac{1}{2} CV^2 \left( \frac{K^2 + 1}{K} \right)</math></p> <p style="padding: 10px 0 0 20px;"><math>\therefore</math> Required ratio = <math>\frac{2CV^2 \cdot K}{CV^2(K^2 + 1)} = \frac{2K}{(K^2 + 1)}</math></p>	Formula for energy stored	$\frac{1}{2}$	Energy stored before	1	Energy stored after	1	Ratio	$\frac{1}{2}$	<p><math>\frac{1}{2}</math></p> <p><math>\frac{1}{2}</math></p> <p><math>\frac{1}{2}</math></p> <p><math>\frac{1}{2}</math></p> <p><math>\frac{1}{2}</math></p> <p><math>\frac{1}{2}</math></p>	<b>3</b>
Formula for energy stored	$\frac{1}{2}$										
Energy stored before	1										
Energy stored after	1										
Ratio	$\frac{1}{2}$										
Q20	<table border="1" style="width: 100%; border-collapse: collapse;"> <tbody> <tr> <td style="padding: 2px;">Formula for energy stored</td> <td style="text-align: right; padding: 2px;"><math>\frac{1}{2}</math></td> </tr> <tr> <td style="padding: 2px;">Energy stored before</td> <td style="text-align: right; padding: 2px;">1</td> </tr> <tr> <td style="padding: 2px;">Energy stored after</td> <td style="text-align: right; padding: 2px;">1</td> </tr> <tr> <td style="padding: 2px;">Ratio</td> <td style="text-align: right; padding: 2px;"><math>\frac{1}{2}</math></td> </tr> </tbody> </table> <p style="padding: 10px 0 0 20px;">Energy stored = <math>\frac{1}{2} CV^2 (= \frac{1}{2} \frac{Q^2}{C})</math></p> <p style="padding: 10px 0 0 20px;">Net capacitance with switch S closed = <math>C + C = 2C</math></p> <p style="padding: 10px 0 0 20px;"><math>\therefore</math> Energy stored = <math>\frac{1}{2} \times 2C \times V^2 = CV^2</math></p> <p style="padding: 10px 0 0 20px;">After the switch S is opened, capacitance of each capacitor = <math>KC</math></p>	Formula for energy stored	$\frac{1}{2}$	Energy stored before	1	Energy stored after	1	Ratio	$\frac{1}{2}$	<p><math>\frac{1}{2}</math></p> <p><math>\frac{1}{2}</math></p> <p><math>\frac{1}{2}</math></p>	
Formula for energy stored	$\frac{1}{2}$										
Energy stored before	1										
Energy stored after	1										
Ratio	$\frac{1}{2}$										



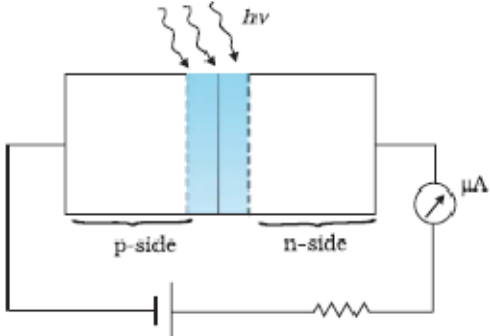

	<p>∴ Energy stored in capacitor A = <math>\frac{1}{2}KCV^2</math></p> <p>For capacitor B,</p> <p>Energy stored = <math>\frac{1}{2} \frac{Q^2}{KC} = \frac{1}{2} \frac{C^2V^2}{KC} = \frac{1}{2} \frac{CV^2}{K}</math></p> <p>∴ Total Energy stored = <math>\frac{1}{2}KCV^2 + \frac{1}{2} \frac{CV^2}{K} = \frac{1}{2}CV^2 \left( K + \frac{1}{K} \right)</math></p> <p style="text-align: center;"><math>= \frac{1}{2}CV^2 \left( \frac{K^2 + 1}{K} \right)</math></p> <p>∴ Required ratio = <math>\frac{2CV^2 \cdot K}{CV^2(K^2 + 1)} = \frac{2K}{(K^2 + 1)}</math></p>	<p>1/2</p> <p>1/2</p> <p>1/2</p>	<p style="text-align: center;"><b>3</b></p>										
<p>Q21</p>	<table border="1" style="width: 100%; border-collapse: collapse;"> <tr> <td style="padding: 5px;">a) Correct Choice of R</td> <td style="text-align: right; padding: 5px;">1/2</td> </tr> <tr> <td style="padding: 5px;">Reason</td> <td style="text-align: right; padding: 5px;">1/2</td> </tr> <tr> <td style="padding: 5px;">b) Circuit Diagram</td> <td style="text-align: right; padding: 5px;"><b>1</b></td> </tr> <tr> <td style="padding: 5px;">Working</td> <td style="text-align: right; padding: 5px;">1/2</td> </tr> <tr> <td style="padding: 5px;">I-V characteristics</td> <td style="text-align: right; padding: 5px;">1/2</td> </tr> </table> <p>a) R would be increased.</p> <p style="padding-left: 40px;">Resistance of S (a semi conductor) decreases on heating.</p> <p>b) Photodiode diagram</p> <div style="text-align: center;">  </div> <p>When the photodiode is illuminated with light (photons) (with energy (<math>h\nu</math>) greater than the energy gap (<math>E_g</math>) of the semiconductor), then electron-hole pairs are generated due to the</p>	a) Correct Choice of R	1/2	Reason	1/2	b) Circuit Diagram	<b>1</b>	Working	1/2	I-V characteristics	1/2	<p>1/2</p> <p>1/2</p> <p style="text-align: center;"><b>1</b></p>	
a) Correct Choice of R	1/2												
Reason	1/2												
b) Circuit Diagram	<b>1</b>												
Working	1/2												
I-V characteristics	1/2												

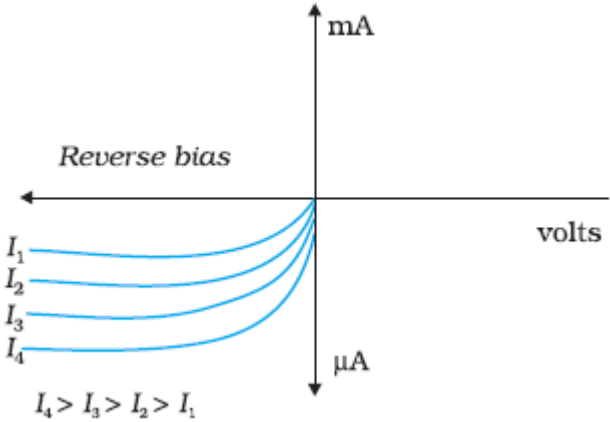
	<p>absorption of photons. Due to junction field, electrons and holes are separated before they recombine. Electrons are collected on n-side and holes are collected on p-side giving rise to an emf.</p> <p>When an external load is connected, current flows.</p> <p>V-I Characteristics of the diode</p> 	<p>1/2</p> <p>1/2</p>	<p>3</p>								
<p>Q22</p>	<table border="1" data-bbox="228 1058 1073 1286"> <tr> <td>(a) Statement of Biot Savart law</td> <td>1</td> </tr> <tr> <td>Expression in vector form</td> <td>1/2</td> </tr> <tr> <td>(b) Magnitude of magnetic field at centre</td> <td>1</td> </tr> <tr> <td>Direction of magnetic field</td> <td>1/2</td> </tr> </table> <p>(a) It states that magnetic field strength, <math>d\vec{B}</math>, due to a current element, <math>I d\vec{l}</math>, at a point, having a position vector <math>\mathbf{r}</math> relative to the current element, is found to depend (i) directly on the current element, (ii) inversely on the square of the distance <math> \mathbf{r} </math>, (iii) directly on the sine of angle between the current element and the position vector <math>\mathbf{r}</math>.</p> <p>In vector notation,</p> $d\vec{B} = \frac{\mu_0}{4\pi} \frac{I d\vec{l} \times \vec{r}}{ \vec{r} ^3}$ <p>Alternatively,</p> $\left( d\vec{B} = \frac{\mu_0}{4\pi} \frac{I d\vec{l} \times \hat{r}}{ \vec{r} ^2} \right)$	(a) Statement of Biot Savart law	1	Expression in vector form	1/2	(b) Magnitude of magnetic field at centre	1	Direction of magnetic field	1/2	<p>1</p> <p>1/2</p>	
(a) Statement of Biot Savart law	1										
Expression in vector form	1/2										
(b) Magnitude of magnetic field at centre	1										
Direction of magnetic field	1/2										



	<p>(b) <math>B_p = \frac{\mu_0 \times 1}{2R} = \frac{\mu_0}{2R}</math> (along z – direction)</p> $B_Q = \frac{\mu_0 \times \sqrt{3}}{2R} = \frac{\mu_0 \sqrt{3}}{2R}$ (along x – direction) $\therefore B = \sqrt{B_p^2 + B_Q^2} = \frac{\mu_0}{R}$ <p>This net magnetic field <b>B</b>, is inclined to the field <b>B<sub>p</sub></b>, at an angle <math>\theta</math>, where</p> $\tan \theta = \sqrt{3}$ $(\theta = \tan^{-1} \sqrt{3} = 60^\circ)$ <p>(in XZ plane)</p>	<p><math>\frac{1}{2}</math></p> <p><math>\frac{1}{2}</math></p> <p><math>\frac{1}{2}</math></p>	<p><b>3</b></p>
--	---	---	-----------------

## SECTION D

Q23	<table border="1" style="width: 100%;"> <tr> <td>a) Name of the installation, the cause of disaster</td> <td><math>\frac{1}{2} + \frac{1}{2}</math></td> </tr> <tr> <td>b) Energy release process</td> <td>1</td> </tr> <tr> <td>c) Values shown by Asha and mother</td> <td>1+1</td> </tr> </table> <p>a) (i) Nuclear Power Plant:/'Set-up' for releasing Nuclear Energy/Energy Plant (Also accept any other such term)</p> <p>(ii) Leakage in the cooling unit/ Some defect in the set up.</p> <p>b) Nuclear Fission/Nuclear Energy Break up (/ Fission) of Uranium nucleus into fragments</p> <p>c) Asha: Helpful, Considerate, Keen to Learn, Modest Mother: Curious, Sensitive, Eager to Learn, Has no airs (Any one such value in each case)</p>	a) Name of the installation, the cause of disaster	$\frac{1}{2} + \frac{1}{2}$	b) Energy release process	1	c) Values shown by Asha and mother	1+1	<p><math>\frac{1}{2}</math></p> <p><math>\frac{1}{2}</math></p> <p><b>1</b></p> <p><b>1</b></p> <p><b>1</b></p>	<p><b>4</b></p>
a) Name of the installation, the cause of disaster	$\frac{1}{2} + \frac{1}{2}$								
b) Energy release process	1								
c) Values shown by Asha and mother	1+1								

## SECTION E

Q24	<table border="1" style="width: 100%;"> <tr> <td>a) Identification</td> <td><math>\frac{1}{2}</math></td> </tr> <tr> <td>b) Identifying the curves</td> <td>1</td> </tr> <tr> <td>Justification</td> <td><math>\frac{1}{2}</math></td> </tr> <tr> <td>c) Variation of Impedance with frequency</td> <td><math>\frac{1}{2}</math></td> </tr> <tr> <td>Graph</td> <td><math>\frac{1}{2}</math></td> </tr> <tr> <td>d) Expression for current</td> <td>1<math>\frac{1}{2}</math></td> </tr> <tr> <td>Phase relation</td> <td><math>\frac{1}{2}</math></td> </tr> </table> <p>a) The device X is a capacitor</p>	a) Identification	$\frac{1}{2}$	b) Identifying the curves	1	Justification	$\frac{1}{2}$	c) Variation of Impedance with frequency	$\frac{1}{2}$	Graph	$\frac{1}{2}$	d) Expression for current	1 $\frac{1}{2}$	Phase relation	$\frac{1}{2}$	<p><math>\frac{1}{2}</math></p>	
a) Identification	$\frac{1}{2}$																
b) Identifying the curves	1																
Justification	$\frac{1}{2}$																
c) Variation of Impedance with frequency	$\frac{1}{2}$																
Graph	$\frac{1}{2}$																
d) Expression for current	1 $\frac{1}{2}$																
Phase relation	$\frac{1}{2}$																



- b) Curve B  $\longrightarrow$  voltage  
 Curve C  $\longrightarrow$  current  
 Curve A  $\longrightarrow$  power

$\frac{1}{2}$   
 $\frac{1}{2}$

Reason: The current leads the voltage in phase, by  $\pi/2$ , for a capacitor.

$\frac{1}{2}$

c)  $X_c = \frac{1}{\omega C}$  ( $X_c \propto \frac{1}{\omega}$ )

$\frac{1}{2}$

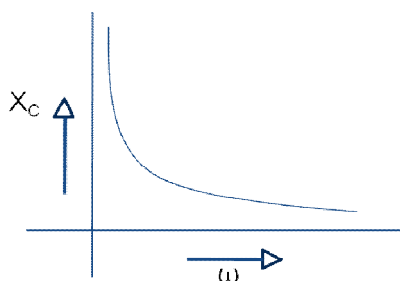

$\frac{1}{2}$

d)  $V = V_o \sin \omega t$

$Q = CV = CV_o \sin \omega t$

$I = \frac{dq}{dt} = \omega C V_o \cos \omega t$

$= I_o \sin(\omega t + \pi/2)$

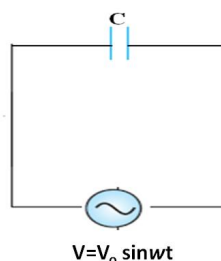

$\frac{1}{2}$

$\frac{1}{2}$

$\frac{1}{2}$

$\frac{1}{2}$

Current leads the voltage, in phase, by  $\pi/2$

(Note : If the student identifies the device X as an Inductor but writes correct answers to parts (c) and (d) (in terms of an inductor), the student be given full marks for (only) these two parts )

**OR**

a) Labelled diagram of ac generator	1
Expression for emf	2
b) Formula for emf	$\frac{1}{2}$
Substitution	$\frac{1}{2}$
Calculation of emf	1

5

a)

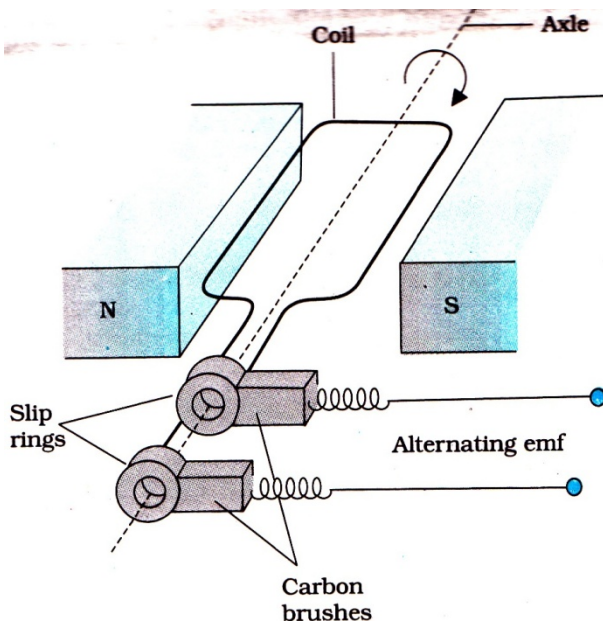

1

Let  $\omega$  be the angular speed of rotation of the coil. We then have

$$\phi(t) = NBA \cos \omega t$$

1/2

$$\therefore E = -\frac{d\phi}{dt}$$

$$= NBA\omega \sin \omega t$$

1/2

$$= E_0 \sin \omega t \quad (E_0 = NBA\omega)$$

1

b) Induced emf =  $Blv$

1/2

$$\therefore E = 0.3 \times 10^{-4} \times 10 \times 5 \text{ volt}$$

1/2

$$E = 1.5 \times 10^{-3} \text{V} (= 1.5\text{mV})$$

1

5

Q25

a) Definition of wavefront	1/2
Verifying laws of refraction by Huygen's principle	3
b) Polarisation by scattering	1/2
Calculation of Brewster's angle	1

a) The wavefront is the common locus of all points which are in phase(/surface of constant phase)

1/2

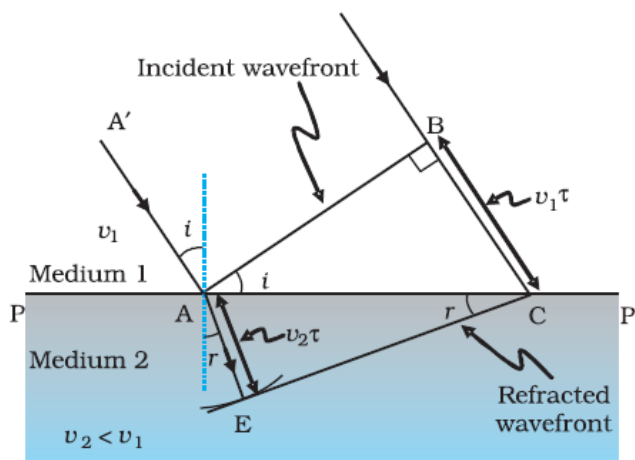

1

Let a plane wavefront be incident on a surface separating two media as shown. Let  $v_1$  and  $v_2$  be the velocities of light in the rarer medium and denser medium respectively. From the diagram

$$BC = v_1 t \text{ and } AD = v_2 t$$

1/2

$$\sin i = \frac{BC}{AC} \text{ and } \sin r = \frac{AD}{AC}$$

1/2

$$\therefore \frac{\sin i}{\sin r} = \frac{BC}{AD} = \frac{v_1 t}{v_2 t}$$

1/2

$$= \frac{v_1}{v_2} = a \text{ constant}$$

1/2

This proves Snell's law of refraction.

b) When unpolarised light gets scattered by molecules, the scattered light has only one of its two components in it. (Also accept diagrammatic representation)

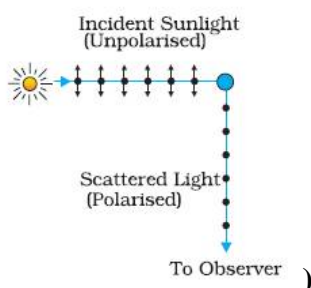

1/2

We have,  $\mu = \tan i_B$

$$\therefore \tan i_B = 1.5$$

$$\therefore i_B = \tan^{-1} 1.5$$

(/56.3°)

**OR**

a) Ray diagram	1
Expression for power	2
b) Formula	1/2
Calculation of speed of light	1 1/2

a)

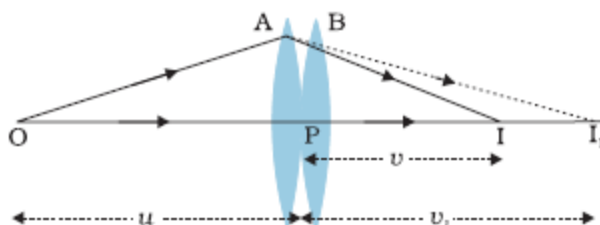

Two thin lenses, of focal length  $f_1$  and  $f_2$  are kept in contact. Let O be the position of object and let  $u$  be the object distance. The distance of the image (which is at  $I_1$ ), for the first lens is  $v_1$ .

This image serves as object for the second lens.

Let the final image be at I. We then have

$$\frac{1}{f_1} = \frac{1}{v_1} - \frac{1}{u}$$

$$\frac{1}{f_2} = \frac{1}{v} - \frac{1}{v_1}$$

Adding , we get

$$\frac{1}{f_1} + \frac{1}{f_2} = \frac{1}{v} - \frac{1}{u} = \frac{1}{f}$$

$$\therefore \frac{1}{f} = \frac{1}{f_1} + \frac{1}{f_2}$$

$$\therefore P = P_1 + P_2$$

1/2

1/2

5

1

1/2

1/2

1/2

1/2

	<p>b) At minimum deviation</p> $r = A/2 = 30^\circ$ <p>We are given that</p> $i = \frac{3}{4}A = 45^\circ$ $\therefore \mu = \frac{\sin 45^\circ}{\sin 30^\circ} = \sqrt{2}$ <p><math>\therefore</math> Speed of light in the prism <math>= \frac{c}{\sqrt{2}}</math> (<math>\cong 2.1 \times 10^8 \text{ ms}^{-1}</math>)</p> <p>[Award <math>\frac{1}{2}</math> mark if the student writes the formula:  <math display="block">\mu = \frac{\sin(A + D_m)/2}{\sin(A/2)}</math> but does not do any calculations.]</p>	<p><math>\frac{1}{2}</math></p> <p><math>\frac{1}{2}</math></p> <p><math>\frac{1}{2}</math></p> <p><math>\frac{1}{2}</math></p>	<p><b>5</b></p>
<p>Q26</p>	<div style="border: 1px solid black; padding: 5px; margin-bottom: 10px;"> <p>(a) Derivation of <math>E</math> along the axial line of dipole      2</p> <p>(b) Graph between <math>E</math> vs <math>r</math>      1</p> <p>(c) (i) Diagrams for stable and unstable equilibrium of dipole      <math>\frac{1}{2} + \frac{1}{2}</math></p> <p>(ii) Torque on the dipole in the two cases      <math>\frac{1}{2} + \frac{1}{2}</math></p> </div> <p>(a)</p>  <p>Electric field at P due to charge <math>(+q) = E_1 = \frac{1}{4\pi\epsilon_0} \frac{q}{(r-a)^2}</math>      <math>\frac{1}{2}</math></p> <p>Electric field at P due to charge <math>(-q) = E_2 = \frac{1}{4\pi\epsilon_0} \frac{q}{(r+a)^2}</math>      <math>\frac{1}{2}</math></p> <p>Net electric Field at P <math>= E_1 - E_2 = \frac{1}{4\pi\epsilon_0} \frac{q}{(r-a)^2} - \frac{1}{4\pi\epsilon_0} \frac{q}{(r+a)^2}</math>      <math>\frac{1}{2}</math></p> $= \frac{1}{4\pi\epsilon_0} \frac{2pr}{(r^2 - a^2)^2} \quad (p = q \cdot 2a)$ <p>Its direction is parallel to <math>\vec{p}</math>.      <math>\frac{1}{2}</math></p>	<p><math>\frac{1}{2}</math></p> <p><math>\frac{1}{2}</math></p> <p><math>\frac{1}{2}</math></p> <p><math>\frac{1}{2}</math></p>	





(b)

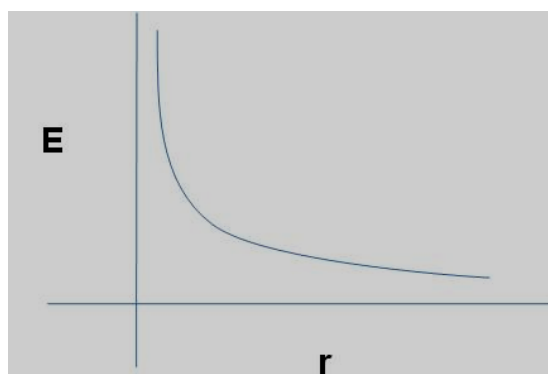

(Note: Award 1/2 mark if the student just writes: For short Dipole =  $\frac{1}{4\pi\epsilon_0} \frac{2p}{r^3}$  without drawing the graph)

(c)

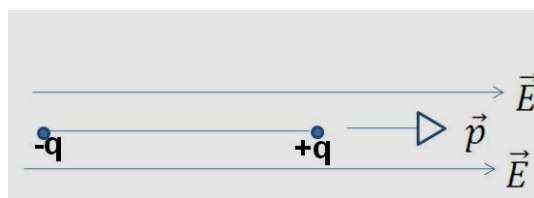

Stable equilibrium



Unstable equilibrium

(Note: Award 1/2 mark only if the student does not draw the diagrams but just writes:

- (i) For stable Equilibrium:  $\vec{p}$  is parallel to  $\vec{E}$ .
- (ii) For unstable equilibrium:  $\vec{p}$  is antiparallel to  $\vec{E}$ )

Torque = 0 for (i) as well as case (ii).

(Also accept,  $\vec{\tau} = \vec{p} \times \vec{E}$  /  $\tau = pE \sin \theta$ )

**OR**

a) Using Gauss's theorem to find E due to an infinite plane sheet of charge	3
b) Expression for the work done to bring charge q from infinity to r	2

1

1/2

1/2

1/2 + 1/2

5

a)

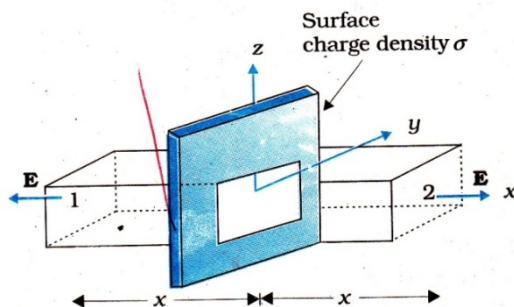

$$\oint E \cdot ds = \frac{q}{\epsilon_0}$$

The electric field  $E$  points outwards normal to the sheet. The field lines are parallel to the Gaussian surface except for surfaces 1 and 2. Hence the net flux  $= \oint E \cdot ds = EA + EA$  where  $A$  is the area of each of the surface 1 and 2.

$$\therefore \oint E \cdot ds = \frac{q}{\epsilon_0} = \frac{\sigma A}{\epsilon_0} = 2EA;$$

$$E = \frac{\sigma}{2\epsilon_0}$$

b)

$$\begin{aligned} W &= q \int_{\infty}^r \vec{E} \cdot d\vec{r} \\ &= q \int_{\infty}^r (-E dr) \\ &= -q \int_{\infty}^r \left( \frac{\sigma}{2\epsilon_0} \right) dr \\ &= \frac{q\sigma}{2\epsilon} |\infty - r| \\ &\Rightarrow (\infty) \end{aligned}$$

 $\frac{1}{2}$  $\frac{1}{2}$ **1****1** $\frac{1}{2}$  $\frac{1}{2}$  $\frac{1}{2}$  $\frac{1}{2}$ **5**